

**SCHEDA TECNICA / TECHNICAL SHEET / FICHE TECHNIQUE / FICHA TECNICA /
TECHNISCHES DATENBLATT / TEHNIČNI LIST**

Diletta

Eva Calòr

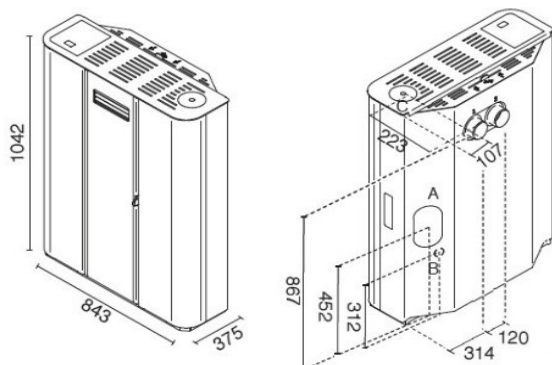

EN 14785 : 2006

A = Scarico fumi / Flue Gas Exhaust / Cheminée / Evacuación de humos / Rauchabzug / Odvod dimnih plinov	80	mm
B = Aria combustione / Combustion air / Air de combustion / Verbrennungsluft / Aire para la combustión / Zrak za zgorevanje	40	mm
C = Scarico fumi superiore / Top Flue outlet / Sortie de Haut de Fumée / Top Abgasstutzen / Salida humos superior / Izpuh dimnih plinov zgoraj	80	mm
1-2 = Aria canalizzata / Ducted air / Air pulsé / Luftkanalsystem / Aire canalizado / Kanaliziran zrak	80	mm

Colori / Colours / Couleurs / Colores / Farben / Barve				
	Nero gofrato / Embossed black / Noir gaufré / Struktur schwarz / Negro gofrado / Reliefna črna			
	Bianco / White / Blanc / Weiss / Blanco / Bela			
	Tortora / Dove grey / Gris tourterelle / Taubengrau / Tórtora / Tortora (svetlo siva)			
	Rosso / Red / Rouge / Rot / Rojo / Rdeča			

Peso / Weight / Poid / Peso / Gewicht / Masa	108	Kg
Capacità di serbatoio / Reservoir capacity / Capacité du réservoir / Capacidad de depósito / Behältergröße / Prostornina vsebnika	13	Kg
Grandezza ambiente riscaldabile / Heatable room volume / Volume chauffable / Tamaño ambiente a calentar / Beheizbare Raumgröße / Prostornina ogrevanega prostora	140/200	mc

	MAX	MIN	
Potenza bruciata / Total heat output / Puissance brulé / Potencia consumida / Verbrennungsleistung / Moč izgorevanja	10,5	3,2	KW
Potenza resa in riscaldamento / Nominal heat output / Puissance nominale / Potencia calorífica / Nennleistung / Izhodna moč pri ogrevanju	9,0	3,0	KW
Potenza resa all'acqua / Water heat output / Puissance a l'eau / Potencia calorífica suministrada al agua / Wasserleistung / Izhodna moč za vodo	----	----	KW
Rendimento / Efficiency / Rendement / Rendimiento / Wirkungsgrad / Izkoristek	88,0	92,0	%
Consumo pellet / Pellet consumption / Consommation de pellets / Consumo pellet / Pelletverbrauch / Poraba peletov	2,2	0,7	Kg/h

Emissioni / Emission / émission / Emisión / Emission / Emisije (13 % O ₂)	0,010	0,045	%
CO	114	285	mg/Nm ³
PM	18	19,5	mg/Nm ³
OGC	2	5	mg/Nm ³
NOx	112	111	mg/Nm ³
Temperatura Fumi / Flue gas Temperature / Temperature des fumees / Temperatura de humos / Abgastemperatur / Temperatura dimnih plinov	206	95	°C
Flusso Gas / Flue gas mass flow rate / Flux gaz combustible / Flujo gas combustible / Brenngasfluss / Pretok plina	5,5	5,5	g/s
Tiraggio Minimo / Fuel draught / Tirage de la cheminee / Tiro de la chimenea / Schornsteinzug / Vlek kamina	12	10	Pa

Distanze da pareti infiammabili / Distance to adjacent combustible materials / Distance de securite aux materiaux combustibles / Distancia de materiales combustibles / Mindestabstand zu entflammbaren Oberflächen / Min. odmik od gorljivih sten	Lato / Sides / Côté / Lado / Seite / S Strani	200	mm
	Retro / Rear / Arrière / Detras / Hinten / Zadaj	50	mm
	Fronte / Front / Avant / Fuente / Frontal / Spredaj	1000	mm

Tensione-Frequenza / Voltage-Frequency / Tension-Fréquence / Tensión alimentación-Frec. / Nennspannung-Nennfrequenz / Napetost-Frekvenca	230 / 50	V / Hz
Potenza elettrica / Rated input power / Puissance nominale électrique / Potencia nominal eléctrica / Elektrische Leistungsaufnahme / Električna poraba energije	360	W